



V e M M A[®]

COMPENSATION PLAN



THE VEMMA REFERRAL BONUS PLAN. THERE ARE TWO FORMS OF INCOME WITH VEMMA.



- IMMEDIATE INCOME
- LONG-TERM INCOME

Our business model is designed to reward those people that promote the Vemma brand products. This is accomplished by devoting almost our entire marketing budget to fund the **Vemma Referral Bonus Plan**. This plan is based on the simple two team-building concept - a left side team and a right side team. Since there are just two teams to build, this creates excitement as new Brand Partners join, one after the other, down team lines, helping more people benefit from the volume and creating greater leverage within the plan.

When you enroll as a Brand Partner and place an Auto-delivery order for any Vemma product worth at least sixty (60) Qualifying Volume (QV), or as we like to call "reward points", you will receive access to the Back Office and a free marketing website. When you encounter someone

wanting to become a Brand Partner, you can enroll them through this marketing website. As soon as you qualify your business by enrolling at least one (1) active Brand Partner on each of your left and right sides (active is defined as having an active 60 reward point minimum Auto-delivery order on file), you are then eligible to earn immediate income.

Best yet, the **Vemma Referral Bonus Plan** pays out a true fifty percent (50%) of the Commissionable Volume (CV) weekly, so you have the opportunity to get paid every week! Your monthly Auto-delivery order will activate your Brand Partner account for four (4) weeks including the volume week in which the order is placed, plus a one (1) week grace period.

IMMEDIATE INCOME



FAST START BONUS

Qualifications: Active with 60 reward point Auto-delivery order on file (Brand Partners with rank of Platinum and above Active with 120 point). Eligible Enrollers will receive the Fast Start Bonus on the first order of those Brand Partners or Consumers whom they personally enrolled. To fund the Fast Start Bonus, each first sale will contribute half of the order's normal reward points. Please see the Cycle Credit Chart for exact Fast Start Bonus amounts.

Fast Start Bonus is subject to compression. If the Enroller is inactive then the first eligible up line Enroller will receive the Fast Start Bonus.

For three (3) months during each calendar year, Vemma will donate a portion of the proceeds from every purchase of Vemma NEXT® to the Children's Miracle Network Hospitals®. The three (3) month period designated for donations to Children's Miracle Network Hospitals will be determined by Vemma.

For Fast Start Bonus and cycle volume information, please refer to the Cycle Credit Chart on page 5.

"Among the many varied channels through which a person today receives information, it is hard to imagine any that carry the credibility, and as a result, the importance of interpersonal communication or word-of-mouth."

Godes & Mayzlin,
Study of Word-of-Mouth
Communication



LONG-TERM INCOME



CYCLE BONUS

Qualifications: Active Brand Partners with 120 reward point Auto-delivery order on file, along with two (2) personally enrolled active Brand Partners, one (1) on each team.

At the end of each volume period (week), Vemma's computers search down your left and right teams and whenever 180 reward points in one team and 360 reward points on the opposite team occur (sides can switch back and forth), Brand Partners are eligible to earn a Cycle Bonus of approximately \$22 - \$25 USD. The weekly cycle value will be determined each week based upon total sales divided by the amount of qualified cycles.

For cycle volume information associated with products, please refer to the Cycle Credit Chart on page 5.

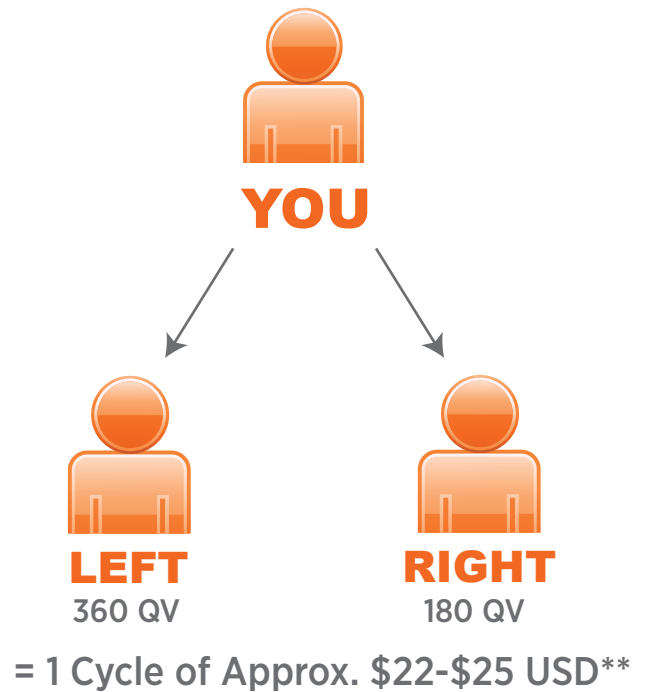

CYCLE CREDIT CHART

Vemma Nutrition Program Purchased	Fast Start Earned	Fast Start Reward Pts	Subsequent Orders Reward Pts
Vemma 1-Pack	\$10 USD	30	60
Vemma 2-Pack	\$20 USD	60	120
Vemma 4-Pack	\$40 USD	120	240
Vemma 10-Pack	\$80 USD	240	420
V2 Fridge Brick	\$10 USD	30	60
V2 Fridge Brick 2-Pack	\$20 USD	60	120
V2 Fridge Brick 4-Pack	\$40 USD	120	240
V2 Fridge Brick 10-Pack	\$80 USD	240	420
Verve Energy Drink ½-Pack	\$5 USD	15	30
Verve Energy Drink 1-Pack	\$10 USD	30	60
Verve Energy Drink 2-Pack	\$20 USD	60	120
Verve Energy Drink 40-Pack	n/a	n/a	600
Verve Energy Shot ½-Pack	\$5 USD	15	30
Verve Energy Shot 1-Pack	\$10 USD	30	60
Verve Energy Shot 2-Pack	\$20 USD	60	120
Vemma NEXT 1-Pack	\$5 USD*	15	30
Vemma NEXT Fridge Brick	\$5 USD*	15	30
Vemma THIRST 1-Pack	\$10 USD	30	60
Vemma THIRST 2-Pack	\$20 USD	60	120
Vemma THIRST 40-Pack	n/a	n/a	950
Bronze Builder Pack	\$50 USD	150	250
Silver Builder Pack	\$100 USD	225	425
Gold Builder Pack	\$200 USD	400	800

*NOTE: A portion of the proceeds of Vemma NEXT will be donated on behalf of Vemma to Children's Miracle Network for three (3) months of the year. Please refer to the Fast Start Bonus for more information.

NOTE: Verve Energy Drink is available in the U.S. and its territories, Australia, Canada, Caribbean, Europe, Japan, Kenya and New Zealand. Verve Energy Shot is available in the U.S. and its territories, Australia, Canada, Japan and New Zealand. Vemma THIRST™ is available in the U.S. and its territories and Australia, Canada, Caribbean, India, Malaysia, New Zealand, Singapore and Taiwan.

CYCLE EARNINGS LEVELS

The cycle earnings levels only applies to the Cycle Bonus and do not affect any other areas of income in the **Vemma Referral Bonus Plan**. Once they reach the maximum cycle level earnings on that position for four (4) consecutive weeks, they will be given one (1) new position above their maxed position. That position will have the same earning level limit, unless they rank advance to the higher rank as specified below. Up to two (2) positions maximum are allowed per Brand Partner, four (4) individual positions per married couple.

Earnings Level up to:	Brand Partner Rank
\$25,000 per week/\$1,300,000 USD per year	Brand Partner - Royal Ambassador
\$30,000 per week/\$1,560,000 USD per year	Star Royal Ambassador
\$35,000 per week/\$1,820,000 USD per year	Pinnacle Leader

Fast Start will pay out on the first purchase of Builder Packs regardless of the order history and the purchase of any Builder Pack that counts towards upgrading the Builder Pack Flag. For more details on the Builder Pack Flag, please see the description in the Momentum Bonus section on page 10.

Brand Partners will not be eligible to receive some bonuses until they have qualified their Brand Partnership by having a 120 reward point Auto-delivery on file and one (1) active Vemma Brand Partner on their left team and one (1) active Vemma Brand Partner on their right team whom they personally enrolled. Brand Partner will be able to accrue volume in their profit leg if they are qualified. However, if an active Brand Partner has four (4) consecutive weeks of non-qualification, the volume in their profit leg only will flush. For every consecutive week after the four (4) week flush that they continue to not qualify, no volume will accumulate on the profit side. Any sales that they have in the power leg of their organization will remain there until they have qualified their Brand Partnership as long as they are active. Brand Partners can accumulate or bank a maximum of 2,000,000 reward points in their power leg.

Brand Partners below the rank of Platinum are considered active if they have an Auto-delivery base order with a 60

reward point minimum order every five (5) weeks. Platinum and above Brand Partners are considered active if they have an Auto-delivery base order with a 120 reward point minimum order every five (5) weeks.

If a Brand Partner has four (4) consecutive volume periods in which they are not active, all accumulated volume in both teams will flush.

At the end of every corporate 52-week period, all power leg volume in excess of fifteen (15) times the total amount of the Brand Partner's most recent four (4) week profit leg volume will be flushed, if that Brand Partner was enrolled prior to week 27. Brand Partners enrolled during or after week 27 will not flush until the following year. At the start of week 1, all power leg volume exceeding the set threshold will be flushed. The threshold is equal to 150,000 reward points or fifteen (15) times the profit leg volume generated during weeks 49 through 52, whichever is greater. The most recent four (4) week profit leg volume is defined as any and all generated volume that occurs in Brand Partner's profit leg during weeks 49 through 52.

After twenty-four (24) consecutive weeks without activity, the Brand Partnership will be terminated.

ENROLLER MATCHING BONUS

Qualifications: Active and qualified with 120 reward points and four (4) personally enrolled active Brand Partners, one (1) on each side of their team, two (2) anywhere else on their team.

The Enroller Matching Bonus pays the Enroller ten percent (10%) on all of their personally enrolled Brand Partners' Cycle Bonus earned amounts. If a Brand Partner does not meet the eligibility requirements to earn it, the Enroller Matching Bonus will compress to the first eligible up line Enroller.

A Brand Partner cannot earn both Enroller Matching Bonus and the Second Tier Matching Bonus on the same downline Brand Partner. In the case of compression of the Enroller Matching Bonus due to the direct Enroller's ineligibility, the Second Tier Matching Bonus will compress as well.

SECOND TIER MATCHING BONUS

Qualifications: Active and qualified with 120 reward points and six (6) personally enrolled active Brand Partners, one (1) on each side of their team, four (4) anywhere on their team.

Brand Partners earn on the people that they personally enrolled, plus they are eligible to earn a ten percent (10%) Matching Bonus on all of their personal enrollees' personally enrolled Brand Partners' Cycle Bonus earned amounts. If a Brand Partner does not meet the eligibility requirements to earn it, the Second Tier Matching Bonus will compress to the first eligible up line Enroller.

A Brand Partner cannot earn both Enroller Matching Bonus and the Second Tier Matching Bonus on the same downline Brand Partner. In the case of compression of the Enroller Matching Bonus due to the direct Enroller's ineligibility, the Second Tier Matching Bonus will compress as well.



TIER MATCHING BONUS CAP

Earnings of the Matching Bonuses up to \$5,000 USD in a four (4) week rank advancement period will not require specific structure or rank qualifications. To be eligible to earn the Matching Bonuses in excess of \$5,000 USD in a four (4) week rank advancement period, a Brand Partner must earn and maintain the "Paid As" rank of Platinum or higher.

"Word-of-mouth messages stand out in a person's mind...Quite simply, we find messages more believable and compelling when we hear them directly from other people, particularly people we know and respect."

Regis McKenna, Founder of The McKenna Group

MOMENTUM BONUS

Qualifications: Active and qualified with 120 reward points and one (1) personally enrolled active Brand Partner in each team. Additional requirements are shown in the table below.

This bonus pays out at the end of each four (4) week rank advancement period based upon the paid ranks achieved during the current or previous rank advancement period. Momentum Bonus is prorated amongst all qualified participants based upon "Paid As" rank. The Momentum

Bonus Pool encompasses approximately three percent (3%) of the sales generated from countries that participate in the Momentum Bonus and does not include orders upon which we paid a Fast Start Bonus. The payout at each level will vary from period to period. Brand Partners can participate in the pools at each Momentum pin level for a period of no longer than twelve (12) months from the date they first achieve that Momentum pin level. Brand Partners who do not meet the requirements for their current paid level may participate in a lower pool for which they meet the requirements.^

MOMENTUM BONUS

"PAID AS" RANK: BRONZE

500 reward points consisting of Auto-delivery and/or Builder Pack orders from enrollership volume on each side of your business.

Max Payout Per Share: Up to \$100

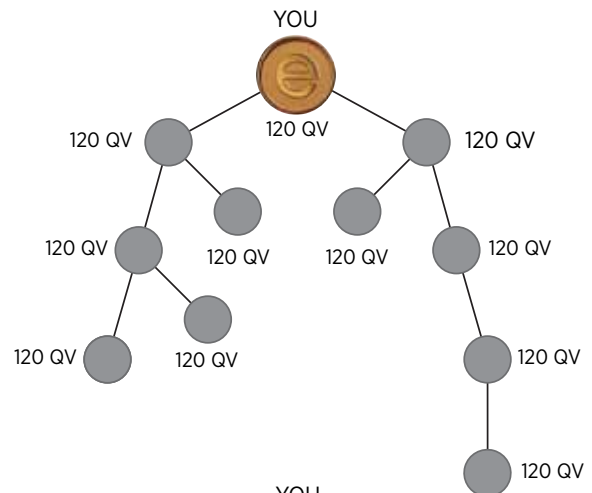

MOMENTUM BONUS

"PAID AS" RANK: SILVER

Bronze* on each side in the enrollment line and 500 reward points consisting of Auto-delivery and/or Builder Pack orders from enrollership volume on each side of your business.

Max Payout Per Share: Up to \$200

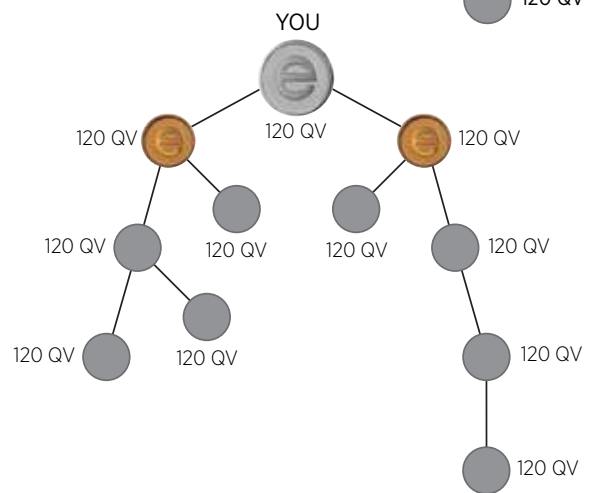

The following countries do not participate in the Momentum: Croatia, Norway, Romania, and Turkey in the European markets and all Asian markets.

^Brand Partners with the "Highest Achieved" and/or "Paid As" rank of Platinum have the maximum payout of \$200.

*The downline Brand Partner's "Paid As" rank must be achieved and maintained by earning a certain number of cycles in a four (4) week rank advancement period as defined in the Rank Advancement section of the **Vemma Referral Bonus Plan**. Those Brand Partners who's "Paid As" rank was achieved by purchasing a Builder Pack will not count toward the rank required in both teams.

MOMENTUM BONUS
BUILDER PACK FLAG

Qualifications: Active and qualified with 120 reward points on Auto-delivery, one (1) personally enrolled active Brand Partner in each team and the purchase of a Builder Pack. Those Brand Partners who choose to start their Vemma Business with an optional Bronze, Silver or Gold Builder Pack will be eligible to earn a Momentum Bonus at the purchased level. This Builder Pack Flag will be honored for 90 days from the day they enroll with Vemma, provided they achieve Momentum Bonus qualifications.

For example: A Brand Partner purchases a Silver Builder Pack, once they are qualified with 500 reward points consisting of Auto-Delivery and/or Builder Pack orders from enrollership volume on each side of their business¹, they would be paid at the Silver level (up to \$200) instead of the Bronze level (up to \$100). Once the 90-day Flag ends, the Brand Partner would be paid normally as qualified.

GLOBAL BONUS POOL BONUS

These twelve (12) week bonus pools encourage team building and cross-line cooperation by rewarding leaders with a bonus that encompasses three percent (3%) of overall Vemma sales. To qualify for a full share of this bonus, Brand Partners must meet or exceed the cycle requirements shown below. Each level of this bonus Brand Partners qualify for, also entitles them to a share of the previous bonus pool up to a share of all five (5) pools.

Pools	%	Half Share	Full Share
Pearl Bonus Pool	.5%	160 Cycles	240 Cycles
Ruby Bonus Pool	.5%	400 Cycles	600 Cycles
Sapphire Bonus Pool	.5%	1,000 Cycles	1,500 Cycles
Emerald Bonus Pool	.5%	2,000 Cycles	3,000 Cycles
Royal Bonus Pool	1%	5,000 Cycles	10,000 Cycles

¹Momentum Bonus structure requirements are waived during the Builder Pack Flag period.

ONE-TIME RANK ADVANCEMENT REWARDS

After qualifying at a new rank for two (2) consecutive four (4) week Rank Advancement periods, a one-time bonus will pay out. These bonuses increase at each rank with the following rewards:

Two Consecutive Four (4) Week Periods

Silver	\$100 USD
Gold	\$250 USD
Diamond	\$500 USD
Platinum	\$750 USD
Star Platinum	\$1,000 USD
Executive	\$1,500 USD
Star Executive	\$2,000 USD

After qualifying at a new rank for six (6) consecutive four (4) week Rank Advancement periods, a one-time bonus will pay out for those Brand Partners who maintain a minimum of one “Paid As” Star Platinum in their personally enrolled downline on each team of their business. These bonuses increase at each rank with the following rewards:

Six Consecutive Four (4) Week Periods

Presidential	\$3,000 USD
Star Presidential	\$5,000 USD
Ambassador	\$10,000 USD
Star Ambassador	\$15,000 USD
Royal Ambassador	\$25,000 USD
Star Royal Ambassador	\$100,000 USD
Pinnacle Leader	\$250,000 USD

**TOTAL POSSIBLE PAYOUT:
\$414,100.00**

RANK ADVANCEMENT AWARD LEVELS













Rank Advancement and other recognition will be based on four (4) week periods and calculated when bonuses are run for the last week of the four (4) week period. This recognition will be posted in your Vemma Back Office approximately two (2) weeks after the bonus run.

By earning a certain number of cycles in a four (4) week period, Brand Partners can achieve various ranks and be recognized as a Leader!

Leader Rank	Qualifications	Number of cycles in a four (4) week period
	Bronze	1
	Silver	5
	Gold	10
	Diamond	20

ELITE RANKINGS

	Platinum	50
	Star Platinum	75
	Executive	100
	Star Executive	175
	Presidential	250
	Star Presidential	375
	Ambassador	500
	Star Ambassador	1000
	Royal Ambassador	2000
	*Star Royal Ambassador	4000
	**Pinnacle Leader	6000

*In addition to earning 4,000 cycles in a four (4) week rank advancement period, to be "Paid As" a Star Royal Ambassador Brand Partner, you must have two (2) Presidential enroller legs on each side.

**In addition to earning 6,000 cycles in a four (4) week rank advancement period, to be "Paid As" a Pinnacle Leader Brand Partner, you must have three (3) Presidential enroller legs on each side.

GLOSSARY OF TERMS

CV/QV – REWARD POINTS

Equal in the **Vemma Referral Bonus Plan**, both Commissionable Volume (CV) and Qualifying Volume (QV) are also known as “reward points”. The value associated to the specific product that allows you to build cycles and earn bonuses.

ENROLLER

When you introduce a new person to the Vemma opportunity and sign them up, you are the Enroller. Your Enroller is the person who introduced you to Vemma.

SPONSOR

The term Sponsor refers to the person immediately above you in the tree structure. You are the Sponsor of the two (2) people immediately below you, on each side of your team.

AUTO-DELIVERY

Auto-delivery is a recurring monthly order that is delivered to you each month saving you the trouble of having to call in or go online.

QUALIFY

Each Brand Partnership must be qualified to earn bonuses. You qualify your Brand Partnership by being active with 120 reward point Auto-delivery order and personally enrolling one (1) Brand Partner on your left side and one (1) Brand Partner on your right side, each meeting the active requirements based on individual rank.

ACTIVE

In order to be considered active, you must have an Auto-delivery base order with a 60 reward point minimum order every five (5) weeks. Platinum and above are considered active if they have an Auto-delivery base order with 120 reward points every five (5) weeks. A 60 reward point or 120 reward point order will activate your account for four (4) volume periods including the volume week in which the order is placed, plus one (1) volume week grace period. As an active Brand Partner, you can accrue volume from sales that occur under you in your power leg.

ENROLLMENT LINE

Those who are connected by being personally enrolled. For example, your personally enrolled Brand Partners and their personally enrolled Brand Partners are part of an enrollment line.

ENROLLERSHIP VOLUME

This refers to all volume that originates from your activity of enrolling a Brand Partner and helping them grow their teams. Any spillover or banked volume is excluded from this type of volume for the purpose of the Momentum Bonus.

TWO TEAM REQUIREMENTS



ELITE BALANCED BUILDING REQUIREMENTS

Balanced Building requirements apply to Vemma Brand Partners who are “Paid As” Presidential rank or above. Affected Brand Partners will be required to maintain a specific minimum structure within their personally enrolled downline on both sides of their organization to continue to receive one hundred percent (100%) of their Cycle Bonus and Global Bonus Pools share earnings. All contributions from each week are used to increase the company-wide cycle point value in future weeks.

“Buzz is the aggregate of all person-to-person communication about a particular product, service or company at any point in time.”

Emanuel Rosen, *The Anatomy of Buzz*

VEMMA ELITE STRUCTURE REQUIREMENTS

Elite Brand Partner "Paid As" Rank	Personally Enrolled Downline Rank* requirement for each team	Time in which to meet requirement after Elite rank achieved	% of Cycle Bonus/Global Bonus Pools Earnings withheld if not met**
Presidential Star Presidential	Star Platinum or Above	12 weeks	10%
Ambassador Star Ambassador Royal Ambassador Star Royal Ambassador Pinnacle Leader	Star Executive or Above	24 weeks	20%

* Personally enrolled downline rank refers to any Brand Partner in your enrollment downline.

**If you do not meet the Balanced Building requirements for your "Paid As" rank and you do not meet the requirements for a lower rank, the contribution will be at the higher percentage. For example, if someone is "Paid As" Ambassador and does not meet Balanced Building requirements for Ambassador and Presidential ranks by their deadline, the total percentage withheld will be twenty percent (20%). Those Brand Partners "Paid As" Ambassador and higher rank who meet the Presidential Rank requirements, but not the Ambassador Rank requirements will contribute ten percent (10%) of their Cycle Bonus earnings.

These requirements are individual and not cumulative. For example, if someone is growing quickly and reaches Presidential and then advances to Ambassador rank the next four (4) week qualifying cycle, that does NOT waive the twelve (12) weeks to develop a Star Platinum. Additionally, the clock will start for the Ambassador requirement twenty-four (24) weeks from that rank advancement date.

PLEASE NOTE: Maintaining the leader ranks in both teams means that although a Brand Partner may meet the qualified pin requirement, if the qualified level is not MAINTAINED on a monthly basis, the Brand Partner will be treated as if the level was not attained and forfeit the corresponding portion of their cycle bonus income until it becomes qualified again.